

ProX[®]

Live Performance Gear

ProX Trussing/Rigging Safety Guide

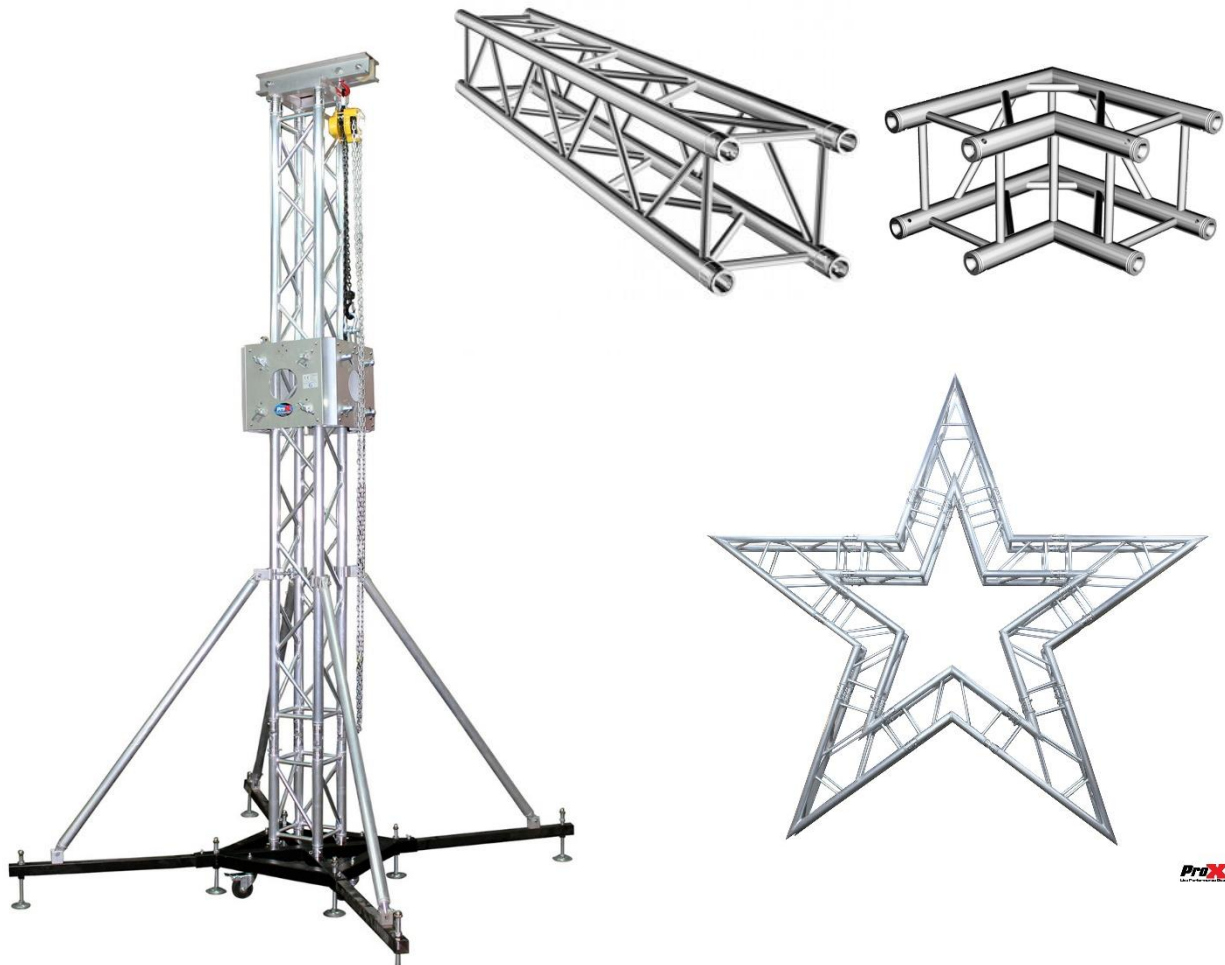

Notice: Portions Copyright ©2017-2019 Xstatic Pro, Inc. ProX Live Performance Gear believes that the information contained in this safety guide is accurate in all respects. However Information, specifications, diagrams, images, and instructions herein are subject to change without notice. The ProX logo and identifying product names and numbers herein are trademarks of Xstatic Pro, Inc. Copyright protection claimed includes all forms and matters of copyrightable materials and information now allowed by statutory or judicial law or hereinafter granted. Product names used in this document may be trademarks or registered trademarks of their respective companies and are hereby acknowledged. All non- ProX brands and product names are trademarks or registered trademarks of their respective companies.

Disclaimer: *Xstatic Pro, Inc., ProX Live Performance Gear and all affiliated companies hereby disclaim any and all liabilities for property, equipment, building, and damages, injuries to any persons, and direct or indirect economic loss associated with the use or reliance of any information contained within this document, and/or as a result of the improper, unsafe, insufficient and negligent assembly, installation, rigging, and usage of this product. The installation, usage and disassembly of trussing systems are an inherently dangerous activity.*

Rigging systems are perhaps the most deceptively complex elements in event production. What may appear to a layperson as a haphazard pile of cables, shackles, and truss work is in all likelihood an intricately-designed and well-engineered structure, capable of supporting equipment many times its own weight. Similarly, there's more to the practice of rigging than simply bolting things together and letting it fly. It's a highly-skilled discipline that is equal parts fabrication, engineering, and art. This difference between perception and reality can lead many to underestimate the safety risks that rigging presents, both as an object and an activity.

*The importance of safe rigging cannot be overstated. Due to its aerial placement and the physical demands placed upon it, accidents resulting from structural failure or improper installation of rigging systems can have disastrous consequences. The lives of your performers, audience, and employees may literally hang on the meticulousness of your rigging procedures. The design, loading and installation and teardown should be supervised and performed by qualified persons. Truss load guides are provided by ProX as a convenience to end users. They are NOT a comprehensive list of load factors and are to only be used by qualified and competent riggers as part of their total load calculations. This GUIDE is just that, and NOT to be used as a comprehensive reference manual for rigging and building of trussing structures. **Always consult a licensed and qualified rigger in your region for guidance and design.***

What is Truss? Lighting or Staging truss provides lighting designers the ability to hang LED or moving lights, wherever they desire (within structure limits). Trussing can be found in theaters, concert halls, performance venues and even at tradeshow, arenas and stadiums as well as used to purpose build an outdoor structure. Anywhere live performances are being held you will likely find aluminum truss.

“Sticks” or sections of the truss are connected together to create a structure allowing lighting fixtures, video, audio or other staging equipment to be hung with ease. Trussing comes in many different lengths and configurations and when all connected together can make longer spans or different shapes.

Construction of Truss: You will general find stage/lighting trusses made from Aluminum or Steel.

1. Aluminum, because it is durable with a great load/weight ratio, its lighter weight and consequently easier to transport, is the most likely choice for use in concert or stage productions. It is quick and easy setup and teardown.
2. Installations that are permanent and generally indoors and where high load ratings are required steel truss is may be chosen.

No matter what your project entails, it is very important to know the load ratings of your truss and always deal with professionals for your design needs. Trussing should never be an afterthought, keep it top of mind.

Components of ProX Trussing:

- Chords: The 4 round (2" - 50mm) tubes that form the outer shape
- Internal Diagonal Members: The 3/4" angled tubes that provide bracing for the chords
- Vertical/Horizontal Members: The straight tubes (either 3/4" or 2") that provide bracing at each end
- Truss Ladder: A type of truss that has one side with horizontal members (2") that provide a ladder side
- Spigot Connection: The ends of the trussing that are connected with a double ended tapered aluminum conical connector and tapered pins secured by a clip pin or self-locking nut on a threaded pin.

ProX Conical Coupling:

- ✓ Makes all trussing sections **genderless** (either end will go together)
- ✓ Assembles quickly with just basic tools
- ✓ Couplers provide precise alignment of chords at all times
- ✓ The couplers have great strength at high stress points
- ✓ Provides for minim damage to trussing members during assembly
- ✓ Makes the listed length of the individual units the actual working length
- ✓ Industry standard to work with many other brands of trussing

Common Truss Sizes:

ProX truss comes in sectional lengths that provide the ability to be for longer spans or to create different shapes or structures. These truss structures are used to support lighting, audio and video equipment. The most common truss lengths are: 9.84ft (3m), 8.02ft (2.5m), 6.56ft (2m), 4.92ft (1.5m), 3.28ft (1m) and 1.64ft (.5m). ProX truss also is available in many other sizes in increments of .25m & .75m along with bends, corners angles, blocks and much more. For a comprehensive listing of all trussing components visit www.ProXDirect.com

Utilization Terms:

When ProX truss is supported overhead it is generally known as being "flown". If the trussing structure is built on the ground or is part of a larger design that is free standing it is called "ground supported" or a ground support structure.

Applications for Trussing:

Commonly most people think of applications for trussing is concert, stage, theatrical, architectural, trade show and houses of worship. If you look and think further, you will see that ProX trussing is found anywhere audio and lighting fixtures are deployed.

Concerts	Exhibits	Tradeshows	Finish Lines
Stadiums	Theaters	Restaurants	Bars
Arenas	Touring Productions	Movie Sets	..plus many more!
Houses of Worship	Theme Parks	Towers	
DJ Booths	Department Stores	TV Studios	

Manufacturing:

NOTE: Prior to 2001 specific American National Standards that cover the design, manufacture and use of aluminum trusses in the entertainment industry did not exist. ProX has taken steps to assure that 100% of the trussing products that it manufactures is built to the exacting standards of ANSI E1.2 - 2006, for precision fit, load ratings, reliability and consistency.

ProX trussing is fabricated, *in our own factory*, from EN-AWT6 6082 Aluminum consisting of 2-inch round aluminum tubes referred to as chords. Truss sections consist of 4 chords generally referred to as “box trussing”. The diagonal members or webbing in the truss is a smaller diameter round tube (3/4”) of EN-AWT6 6082 Aluminum. All of ProX trussing is precision built by **TUV Certified Welders** in a TUV Certified facility for the ultimate in quality control and safety.



TUV is a 3rd Party Certification Body and a Nationally Recognized Testing Laboratory (NRTL). TUV provides inspections, testing, certification & training, with the ultimate objectives of reliability, safety & high quality.

Understanding the Components of Rigging: Rigging work will often take place along with a group of other activities during set up/breakdown the performance of live entertainment and events. To safely assess all risks it is very important to separate rigging work from other event activities and make sure that controls are in place to provide safe conditions throughout the event cycle. In the USA, OSHA legislation (29 CFR Part 1910 applies to general industry and Part 1926 applies to construction) and also considers rigging as high risk work, specific measures need to be implemented for “**rigging**”. To easier understand these measures in the environment of live performance and events, the process is best described by groups.

Group 1: “Top Rigging”, is a high risk activity. This begins when the elevated work platform is in a lowered position ready to begin the task of attaching additional sections to the structure. This would include, but not inclusive: Adding vertical sections, connecting top points and installing chain motors (either manual or electric). “Top Rigging” ends when all attaching tasks at a height above 6.5 ft. (2 meters) height are finished and the elevated work platform is returned to the low static position.

Group 2: “Ground Work” is not considered “rigging” or a high risk activity for the purposes of this guide. This group includes all work conducted at or below 6.5 ft. (2 meters) with all workers at the ground level. During this group there is *no risk of falling* from height and minimal risk of harm to workers from falling objects. **Ground Work** will include, but not be limited to, the assembling of cross truss, mounting lights and/or AV equipment to the assembled structure to be lifted. Once all the desired equipment is added to the structure and the area cleared, **Ground Work** ends.

Group 3: “Movement” of the structure is “rigging” and again a high risk activity (possibly the most dangerous activity) and the area should be cleared of all persons not actively involved in the **movement** of the structure into the final (high) position. This activity begins whenever the structure is moved to where it would become stationary again (either top or ground).

Factors for safety of these temporary performance/event structures involve:

- Choice of appropriate design (qualified and/or licensed persons) and quality materials
- Proper planning and control of work practices at all times
- Correct positioning on the site including site conditions and ground factors

- Regular inspection of the finished structure during use
- A working plan that provides for routine and emergency procedures
- Monitoring weather conditions during construction **AND** operation of the structure

Recommended Lifting of ProX Trussing:

It is highly recommended that ProX trussing is lifted by our **XT-PickPro550** Lifting Bracket. These

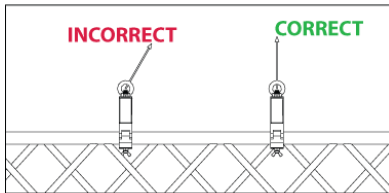
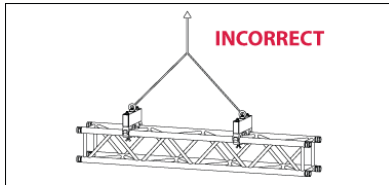

brackets allow horizontal forces between the chords to be ignored and heat resistance is not of significance. A small disadvantage of these brackets is that they cannot be placed directly into the node points but only



close. It can take more time to mount them in the lower chords. For Permanent or Semi-Permanent installations this limitation is irrelevant. Diagonal pull is not permitted when using the **XT-PickPro550**. With a load capacity on a single pick of 550 lbs. (250kg), you can disperse the complete trussing weight with multiple picks for an easy and safe assembly or teardown.

Lifting ProX Truss with Slings: In order to maintain your warranty and for the best safety procedures, ProX trussing lifted with slings must use a **BASKET HITCH**. For this type of slinging, the sling is fed underneath the truss and wrapped once around the lower chord and is passed upward and wrapped once around the upper chord before the ends are connected using a hook or shackle (preferred). This improves the load bearing capacity of the slinging device and distributes the load across all four chords of the truss assembly. The angle should not exceed 120 degrees and the slinging device should be positioned close to a horizontal brace to absorb the compression forces between the upper chords!

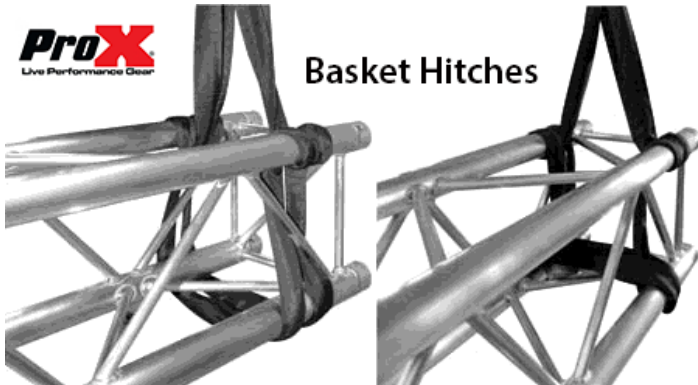

This improves the load bearing capacity of the slinging device and distributes the load across all four chords of the truss assembly. The angle should not exceed 120 degrees and the slinging device should be positioned close to a horizontal brace to absorb the compression forces between the upper chords!

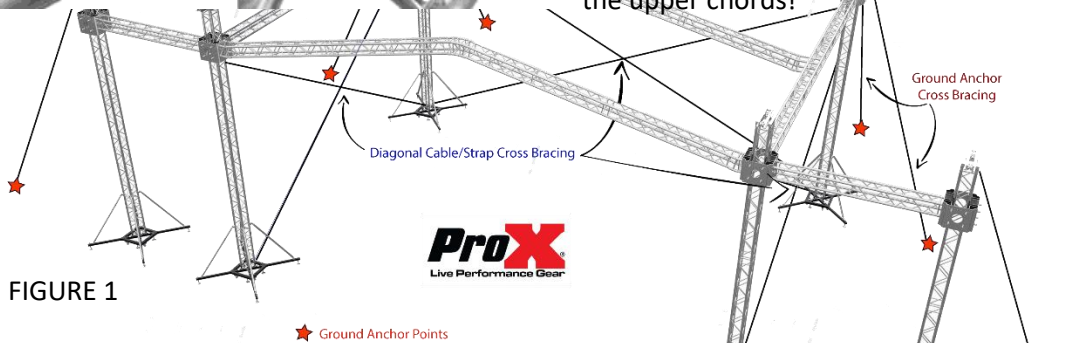
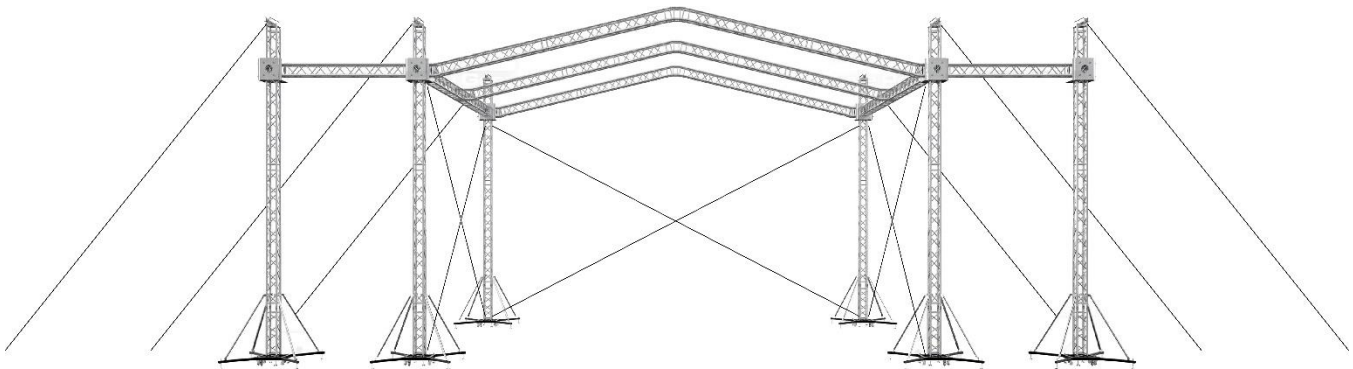

FIGURE 1

IMPORTANT: Diagonal wire rope or strap cross bracing on at least 3 sides of any free standing ground supported structure along with diagonal bracing to ground anchor points along the lateral lines for additional support and wind bracing. Install all bracing prior to installation of roof cover!

Installation of Bracing on Ground Supported Structures: When building a free standing structure there are logical steps that should always be taken to avoid construction and safety issues. Generally speaking all ground supported roofing systems should always be braced with guy cables to resist wind loads. In Figure 1 above, and just below, you will observe the Ground Anchor points and guy cables installed from the tops of the towers and in line with the plane of the trussing structure. These outside braces are integral to a safe lifting system. These guy points are typically from the top of the vertical portions of the complete system and should be installed before lifting the roof structure into place. In the above illustration, the design is intended to provide ONLY the roof and associated cover along with the side sections for the hanging of audio gear and possibly other lighting. Load forces for the roofing area do not include hanging anything from the support structure of the roof without consultation of a design engineer or rigging specialist.

The installation of the outer guy cables should be completed before the roof structure is lifted into place. Once the roof structure is in the final operating position, diagonal cross bracing should be installed to provide additional lateral stability to the entire structure. ProX Trussing packages are created using the loading tables provided by ProX. All installations in the field, due to conditions that cannot be anticipated, should always be verified by a rigging specialist or engineer. ProX cannot be held responsible for proper installation, design, loading, rigging, bracing and many other factors far beyond the control of ProX and is 100% the responsibility of the end user.



Pre-Designed Truss Packages: The sunshade style (pictured above) has been a long time favorite of the touring industry and now with smaller designs is quickly becoming a favorite layout for small to medium sized production needs. With the ability to have rapid assembly, disassembly and easy transport, the Sunshade can be obtained in several pre-designed packages which can be utilized in a variety of locations. More importantly, the system is built from industry standard components adding to its versatility. The ProX XT-SQ packages (XTP-GS403023-PR3-12D shown above) utilize the industry standard F34 square box truss coupled with the ProX XTP-GSBPACK3 ground support packages. Two options are available. The sunshade style (shown above) has the cross stage runs of truss are sloped approximately 7% to form a peak in the center. A canopy is then attached to the components of the main body before lifting and is suitable for many applications. The second is a flat top design (shown on the right) and is typically used without a roof cover. The flat design does also require guy wires and cross brace installation.



Personal Protection: In the construction area of a trussing build all persons should wear Personal Safety Equipment (PSE). Too many people assume that only the persons who are working at height or working in a high risk area must use PSE. All personal entering a worksite should use PSE. This may consist of only shoes with rubber soles and steel noses or hard hats or including a yellow jacket or vest to indicate working personnel. PSE is generally required by OSHA and other local codes (always check your jurisdiction).

Working at Height: Working at heights over 10ft is very common in the entertainment industry, for example to focus lighting or replacing a bulb. In the case of working at height always try to get the work done without climbing by trying to get access to the working area by the use of working platforms whenever possible to decrease the risk this work involves. Sometimes it is just required to use climbing to get access to a certain point in the roof or building structure. In that case always make a personal risk assessment and try to find a method with as little danger as possible involved. Most regulations require that anyone working above the 10ft level should be wearing a full body harness and an arresting shock absorber line. The shock absorber should always be attached to a life-line system and not the truss structure itself. Most trusses will not withstand the forces created by a free fall and arrest line.



Rigging Safely: Most rigging accidents can be avoided by simply adopting good practices, but some are more complicated. The complexity of forces on trussing installations is not something to be judged casually, or worse, just guessed at. When a load is suspended vertically, with gravity being the only force, the function is simple. The sum total of the load is the same as the weight of the object and its accessories being suspended. As a final comment about rigging safety, many people take it for granted that a freestanding structure, such as speaker towers, stage platforms, roofing assembly, and other load-bearing objects are as solid as rock. Fact is, even rocks can move and fall when presented with the right forces. High winds, storms and unstable ground conditions call all add to the “danger zone”. The area around these structures should be marked off to keep spectators and guests out of a potential fall area. It is much better to maintain safety than to deal with the aftermath of a collapsed structure.

The Pre-Designed Truss Sunshade style has been a long time favorite of the touring industry and now with smaller designs is quickly becoming a favorite layout for small to medium sized production needs. With the ability to have rapid assembly, disassembly and easy transport, the Sunshade can be obtained in several pre-designed packages which can be utilized in a variety of locations. More importantly, the system is built from industry standard components adding to its versatility. The ProX XT-SQ packages utilize the industry standard F34 square box truss coupled with the ProX XTP-GSBPACK3 ground support packages. Two options are available. The peaked roof as shown above, and Sunshade (shown above) is patterned after our BFT where the cross stage runs of truss are sloped approximately 5% to form a peak in the center. A canopy is attached to the components of the main body. - making it ideal for many applications.

Loads: When assessing all loads on the fully assembled truss system, full consideration shall be made of weight of all equipment, including, but not limited to, any motors, light and sound equipment, multicore cables, follow-spot chairs, temporary personnel occupancy and reactions from fall protection systems.

Assembly: Proper layout drawings and calculations must be prepared each time that the trussing is to

be used, and should include the following information: 1. accurate overall dimensions, 2. the location of applied loads, 3. the location of suspension points. Reasonable care must be taken to ensure that the trussing is assembled and erected correctly in accordance with the layout drawings and calculations.

During all construction and use, consideration shall be given to the following:

1. Disposition of the loads on the trusses, and whether they are evenly balanced beneath the centerline of the truss, or, as is more often the case, they are mainly concentrated to one side or the other.
2. The increase in weight of the multicore cables towards the point of entry of those cables onto the trussing.
3. The possible dynamic effects on the trusses from the raising and lowering of the suspended equipment, or from the raising and lowering of the completed truss system.
4. The wind forces that may be applied to the truss system during erection, when complete and when in an unloaded as well as fully loaded state. Consideration must be given to items attached to the truss structure such as banners, roof skins, sound and lighting equipment, projection screens, scenery, etc.
5. The effects of changes in temperature during the use of the truss system, of the weight of snow that may lie on the system or any covering, of the possibility of seismic action affecting the overall stability of the system, and of the possibility of accidental impact damage occurring during the period in which the system is operational. The requirements of the Local Building Codes shall be carefully appraised and adhered to in all cases.
6. Any attaching hardware shall be applied in a manner so as not to cause damage.

SAFETY CHECKLIST:

- During planning, ensure you cover the equipment's design, safe installation, use and takedown.
- Staff and any contractors or designers hired to help you should be competent and licensed.
- Make sure the equipment will withstand the environment:
- Consider foreseeable wind loading and any other relevant factors such as ground strength and slope.
- Ensure that the vertical truss section will accommodate the effects of wind loading. In most of these systems, there is a base of sufficient size, possibly with ballast loaded onto the base, to provide for a safety factor to prevent overturning. Some structures rely on base area rather than ballast.
- The use of guy lines will be necessary in most cases.
- It may be possible to de-rate the equipment to take account of wind loads, i.e. use lifting equipment of greater capacity than the weight of the load.
- Check that the structure is built in accordance with the design and/or manufacturer's instructions and load tables.
- Outdoor structures are susceptible to the weather, always monitor and measure the local weather conditions. In adverse weather conditions, know what to do with the equipment to protect its stability. In a lot of circumstances, it may be prudent to provide an exclusion zone [approximately 1.5 times the tower height] around the towers, in case the wind speed exceeds the design-operating speeds and the equipment collapses.
- It is essential that any ballast (if used) remains in place for the entire time that the structure is in use.

- Have procedures in place to prevent unauthorized persons tampering with any winch or brake mechanisms. One way of doing this would be to erect a barrier around the base of the equipment. Another is 24hr security onsite.
- Regularly check all lifting equipment and keep maintained as for safe use.

Dents, Bends, Abrasions and Twists: Considerations for Truss Inspection

Courtesy of *Keith Bohn*, who has more than 25 years of industry experience. He has served on ESTA/PLASA's Working Rigging Group and chairs its task group for ANSI E1.21, outdoor structures for entertainment.

Safety is a huge concern for the live event production industry. This article focuses on a critical component: Inspecting truss. Aluminum truss is widely used in a multitude of applications, from theatre to concerts to exhibitions to outdoor structures. It is purpose-built for very specific loads. Because of that purpose-built aspect, truss doesn't fit into the usual realm of safety factors that entertainment industry veteran's reference for other rigging hardware like shackles, wire rope or hoists. Therefore, considering that the truss can be one of the most crucial components of a rigging system, it is imperative that there are assurances it is in the proper condition for use.

ANSI E1.2-2012

As a reference, we are going to use *ANSI E1.2-2012 Entertainment Technology — Design, Manufacture and Use of Aluminum Trusses and Towers*, as it is the only existing relevant standard for the U.S. There are requirements in this document for the types of inspections that must be conducted for truss as well as their frequency.

Here is a list of the items in the standard that must be inspected:

The following items shall be inspected as described:

Geometry of Trusses and Towers for:

- *Twisting of the Truss or Tower*
- *Racking of the Truss or Tower*
- *Bending of the Truss or Tower*

Chords for:

- *Dents*
- *Bends*
- *Abrasion*

Diagonals for:

- *Dents*
- *Bends*
- *Abrasion*
- *Being Missing*

Connecting Plates (if used) for:

- *Flatness*
- *Deformation or Excessive Wear of Holes*

Pinned Connector Forks (if used) for:

- *Deformation*

Fasteners for:

- *Proper Grade – Must Be Matched*
- *Deformation*
- *Excessive Wear*

Welds for:

- *Breaks, Cracks, or Deformation by Visual Inspection*

Checking Geometry

Starting at the top of the list, there are few different methods to check the geometry of the truss. Your first clue that a section of truss might have a geometry problem would be if it doesn't sit flat on a flat floor. To check further, one test is to place at least two (three is better) straight flat bars on the top the truss section. These flat bars should rest across the top of the chords, perpendicular to the truss section, and extend at least 12 inches beyond the width of the truss on both sides. Then, simply line up all of the bars visually. The bars should all line up. If they don't, you will be able to identify if the truss has geometric issues. For example, if the center bar dips lower on the right, it is likely that the truss has been racked in the center. If there is a successive dip from bar to bar, then the truss is showing signs of a twist. Any time that these three alignment bars *don't* align, you have cause for concern.

Another test for geometry, albeit not necessarily visual, would be to measure the truss diagonally in all faces. The check here is that the measurement from the upper left corner to lower right corner matches the measurement from the upper right corner to the lower left corner. A good tolerance range on this diagonal measurement would be 1/16 inch. Anything more than that, you should contact the manufacturer.

Inspecting Truss Members

Next, we get into the inspection of the individual members. (*If you are unfamiliar with truss nomenclature, see "Configurations" above*).

It is important to check the condition of the chords when evaluating the truss members/components. Chords effectively transfer the load down the length of the truss section. Furthermore, since there are so many other members welded to them, they are not reasonable to repair or replace. Therefore, any damage to the chords is of high concern. All of the truss members have a function and are important, otherwise they wouldn't be there, but the chords are critical for the reasons listed.

When inspecting any of the truss members, there are some consistent things in the list for which the guidelines for inspection remain the same. Dents, bends and abrasions can happen to any of the members, usually due to poor handling, but can also be the result of using the wrong type of clamps, or chain rubbing the truss, or any variety of occurrences. A good rule of thumb to determine if this type of damage is excessive is the 25 percent rule. If any abrasion, bend or dent is deeper than 25 percent of the wall thickness of the material, then the truss needs to be removed from service.

Keep in mind that most members in typical bolted truss are only 1/8 inch thick. So dents, bends and abrasions that are only 1/32 inch deep would fall into this category. You might think that this is overly conservative, but the reality is that the truss is purpose designed and built. When the engineers analyze it, they are considering that the entire shape of material is available for the truss to perform its function. A 25 percent reduction from that is HUGE!

Checking Welds

Before we get into connections, let's talk about welds and the areas around welds. There are a couple of types of weld cracks that you might find when inspecting truss. The first is what you could call a hairline crack. Found in the final tie-in of the weld, these are typically surface cracks and usually run perpendicular to the weld bead around the member. While these are cracks that you should watch to make sure they don't propagate, they aren't typically of structural consequence. However, with all cracks, make sure you consult the manufacturer for advice.

The second type of weld crack would be a stress crack. Typically, proper welds won't show cracks. However, there are situations in certain welded components where this is not true, and the weld can break before the adjacent material. A stress crack typically runs parallel to the weld bead. These are of great concern since this would be an indication of excessive stress on the truss, or at least on that member. As mentioned before, consult with the manufacturer when you discover ANY type of crack.

Another thing to note about welds and weld areas relates to the heat affected zone, or HAZ. Since aluminum truss is fabricated using tempered material, adding excessive heat to it, like welding, changes the material properties. This creates a heat affected zone around the weld. It is in this area that you would be more likely to

see a sign of failure, as it is much weaker than raw un-welded material. In fact, in certain types of destructive truss testing, the mode of failure can be predicted to the HAZ with greater than 90 percent accuracy.

Checking Connections

Lastly are the connections. Whether you are using bolted, spigoted or some other type of connection, proper function of the connection is critical to making sure a completed truss span performs properly.

Many people forget to inspect the hardware when inspecting truss, but the pins and bolts are just as relevant as anything else. When inspecting the hardware itself, you first want to make sure graded hardware matches. If you are using Grade 8 bolts, you need to have Grade 8 nuts. Next, make sure that there isn't excessive wear on the fasteners.

The last item is deformation, and this applies to both the hardware and the connection device itself. Deformation in the hardware is pretty straightforward. You want threads on bolts to be clean, and the pins in spigoted or other pinned truss need to be straight and the proper diameter. A bent or bowed pin is a sure sign of overstress. Deformation in bolted truss plates can take two forms, and you need to inspect for both. First would be the holes themselves. They need to be the appropriate round shape. If it is an oval, there is a problem. Second would be the flatness of the plates. When bolted truss is overstressed, the plates can potentially bow or stretch outward. Once this happens, they will not return to their original shape, and the truss is unsafe.

Spigoted truss is a little different, but you are looking for similar evidence. First, the holes need to be the proper shape. Once again, they need to be their original shape. If you are using spigot or fork connections, make sure that the blades are straight. With spigot-type connections, you also have to look at how the connection is installed in the truss. If they are welded, you should have already inspected them, but again review for cracks. If they are mechanically fastened with roll pins, you need to check to see if the connection is loose. Also, inspect the roll pins themselves. They should be flush to both sides of the tubes, and the holes they are in should be tight all the way around. If you see a gap between the back of the roll pin and the material it is mounted into, this is a sign that the truss has seen excessive loads and needs to be removed from service. Once again, if any questions arise during the inspection process, consult with your manufacturer.

“Frequent” vs. “Periodic”

As noted in the ANSI standard, there are two types of inspections, which are identified, as “frequent” and “periodic.” Frequent inspections are to be conducted every time a truss is used. Before you start rolling your eyes, first consider that you are hanging stuff overhead, but second, consider how long it really takes to do a visual inspection of the truss. This can be done with the truss coming off the truck during load-in. Specifically, the standard calls for the person doing the inspection to be a “Competent” person, who is, and I am paraphrasing, someone who is capable of identifying hazards and authorized to take action. So, presumably, someone who is responsible for hanging equipment over head would also be someone that is competent to conduct these visual truss inspections.

The second type of inspection is a periodic inspection. This inspection is one that requires records to be kept. You should start keeping records of each section of truss when it is first acquired, and then every year thereafter. The records should indicate the date of inspection, and who performed the inspection. As opposed to the competent person for frequent inspection, the periodic inspection requires a “Qualified” person. This is defined as someone that has either through a degree, certificate or extensive experience, demonstrated the ability to solve problems related to truss.

It is further important to note that in addition to being vigilant and responsible regarding safe equipment prior to its use, the record-keeping aspect of truss inspection is vital to protecting yourself in the event of an incident. You can be assured that when an investigation begins, a request for inspection records will be one of the first things to come up. Don't take this lightly, as a response that is inadequate is essentially an admission of irresponsibility.

A LAST WORD OF CAUTION! Truss has long been considered an afterthought, or less important, than the lights or audio or whatever else. But considering that it is a key element to holding all of that equipment in the air, it definitely needs the appropriate attention and respect to ensure safety for the performers, technicians and audience. Be safe out there.



ProX[®]
Live Performance Gear

www.ProXDirect.com

55 Hook Road Building 46, Beyonne, NJ 07002

Phone: 718.237.2299 Fax: 718.237.2318

Email: Info@ProXDirect.com